

THIS DRAWING IS UNPUBLISHED.

RELEASED FOR PUBLICATION

2008

© COPYRIGHT 2008 BY -

ALL RIGHTS RESERVED.

| LOC | DIST | REVISIONS   |                           |           |        |
|-----|------|-------------|---------------------------|-----------|--------|
| P   | LTR  | DESCRIPTION | DATE                      | DWN       | APVD   |
| E   | B    | BA1         | REVISED PER ECO-11-005150 | 29MAR2011 | RK HMR |

1. AVAILABLE WITH DIFFERENT SHAFT LENGTHS AND STYLES AND DIFFERENT BUSHES TO SUIT. SEE DATA SHEET FOR DETAILS. 3/8" x 8mm BUSH (M) WITH 6.35mm FLATTED SHAFT(F) SHOWN.
2. FOR FURTHER INFORMATION SEE DATA SHEET FOR 23 SERIES-SPINDLE OPERATED POTENTIOMETER

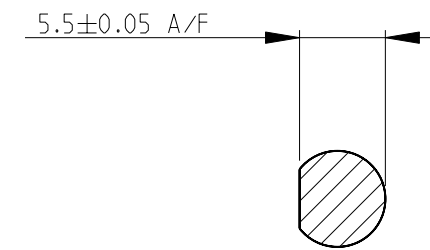
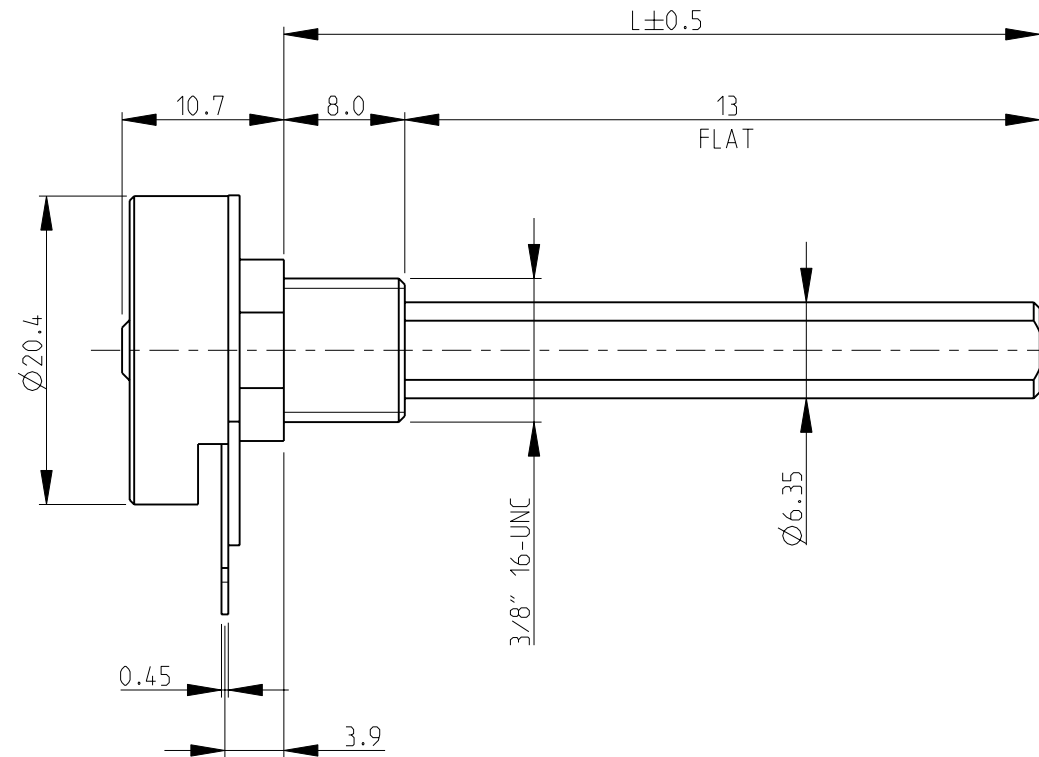
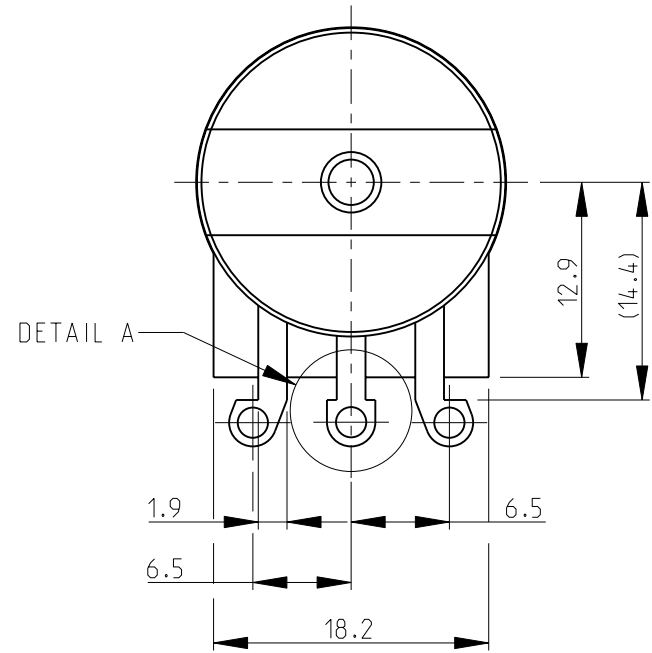

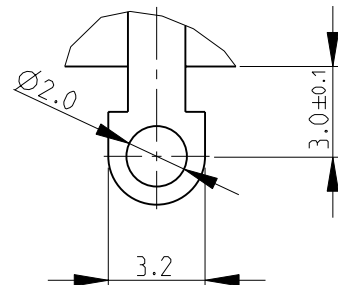

DETAIL A

DETAIL A SCALE 4:1

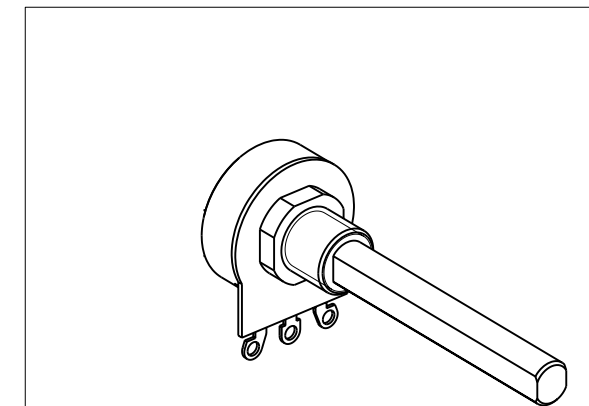

RoHS Compliant



|   |       |          |           |                    |  |       |       |     |       |     |       |     |        |      |      |  |
|---|-------|----------|-----------|--------------------|--|-------|-------|-----|-------|-----|-------|-----|--------|------|------|--|
| THIS DRAWING IS A CONTROLLED DOCUMENT.  |       | DWN      | SUBHASH.M | 30-Jul-08          |  <b>TE Connectivity</b> |       |       |     |       |     |       |     |        |      |      |  |
| DIMENSIONS: mm  |       | CHK      | PRAKASH.S | 30-Jul-08          |  |       |       |     |       |     |       |     |        |      |      |  |
| TOLERANCES UNLESS OTHERWISE SPECIFIED:  |       | APVD     | STEPHEN.P | 30-Jul-08          |  |       |       |     |       |     |       |     |        |      |      |  |
| <table border="1"> <tr><td>0 PLC</td><td>± 0.5</td></tr> <tr><td>1 PLC</td><td>± 0.1</td></tr> <tr><td>2 PLC</td><td>± -</td></tr> <tr><td>3 PLC</td><td>± -</td></tr> <tr><td>4 PLC</td><td>± -</td></tr> <tr><td>ANGLES</td><td>± 5°</td></tr> </table> |       | 0 PLC    | ± 0.5     | 1 PLC              |  | ± 0.1 | 2 PLC | ± - | 3 PLC | ± - | 4 PLC | ± - | ANGLES | ± 5° | NAME |  |
| 0 PLC   | ± 0.5 |          |           |                    |  |       |       |     |       |     |       |     |        |      |      |  |
| 1 PLC   | ± 0.1 |          |           |                    |  |       |       |     |       |     |       |     |        |      |      |  |
| 2 PLC   | ± -   |          |           |                    |  |       |       |     |       |     |       |     |        |      |      |  |
| 3 PLC   | ± -   |          |           |                    |  |       |       |     |       |     |       |     |        |      |      |  |
| 4 PLC   | ± -   |          |           |                    |  |       |       |     |       |     |       |     |        |      |      |  |
| ANGLES  | ± 5°  |          |           |                    |  |       |       |     |       |     |       |     |        |      |      |  |
| MATERIAL -  |       | FINISH - |           | APPLICATION SPEC - | SIZE A3  |       |       |     |       |     |       |     |        |      |      |  |
| -   |       | -        |           | WEIGHT -           | CAGE CODE 00779  |       |       |     |       |     |       |     |        |      |      |  |
| -   |       | -        |           | CUSTOMER DRAWING   | DRAWING NO. 1623763  |       |       |     |       |     |       |     |        |      |      |  |
| -   |       | -        |           | SCALE 2:1          | RESTRICTED TO -  |       |       |     |       |     |       |     |        |      |      |  |
| -   |       | -        |           | SHEET 1 OF 1       | REV BA1  |       |       |     |       |     |       |     |        |      |      |  |